

Fuser

1. Remove the back cover (see [Back cover](#)) and the I/O cover (see [I/O cover](#)).
2. Remove the fuser-cable cover by releasing one tab (callout 1) on the cover, and then rotating the back of the cover toward the center of the printer.

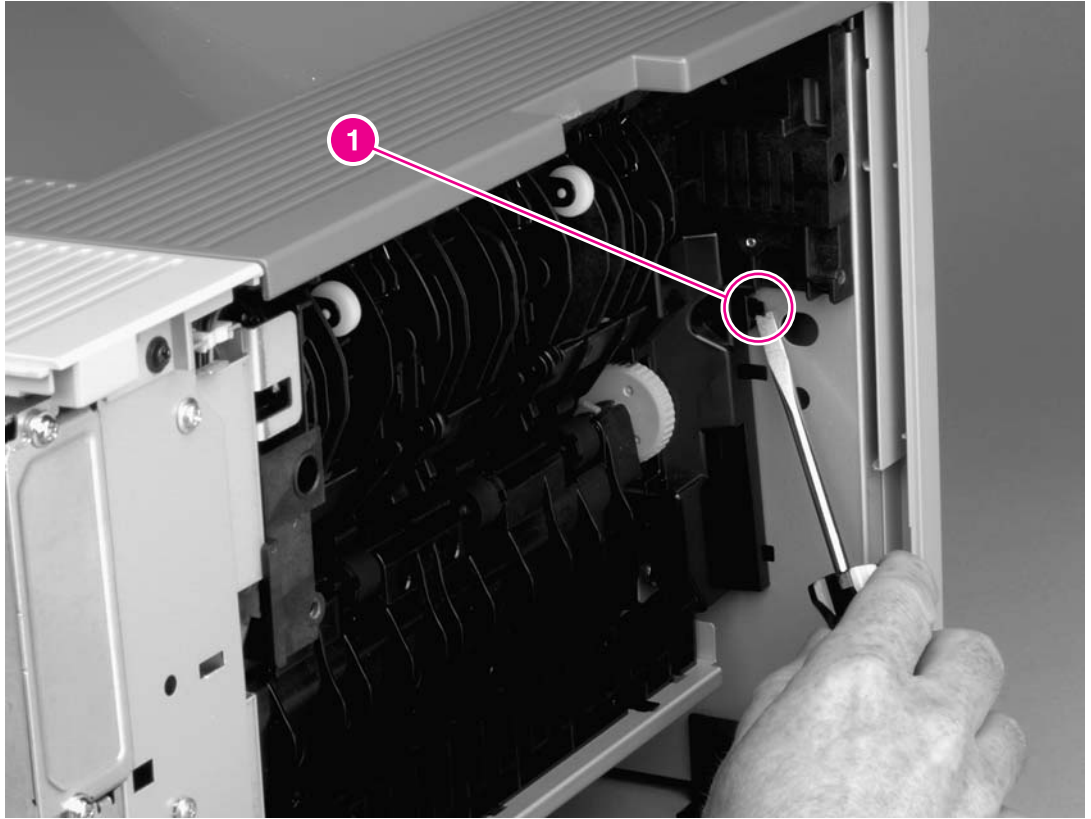

Figure 6-19. Removing the fuser (1 of 5)

3. Remove the duplexer inlet guide by releasing two tabs (callout 2) on the guide, and then sliding the guide toward the back of the printer.

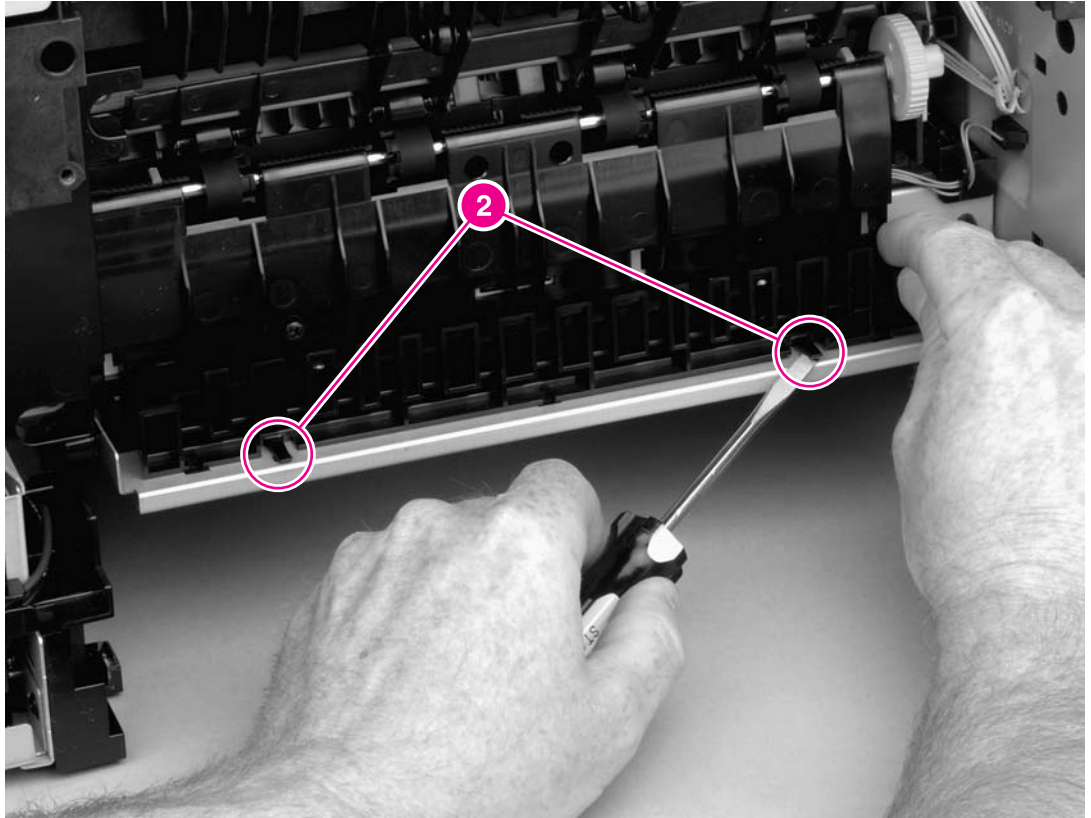

Figure 6-20.

Removing the fuser (2 of 5)

Reinstallation tip

Make sure that both tabs snap back into place when reinstalling the duplexer inlet guide.

4. Disconnect two cables at the left, inside, of the printer (callout 3).

5. Disconnect the fuser cable at the right side of the printer (callout 4).

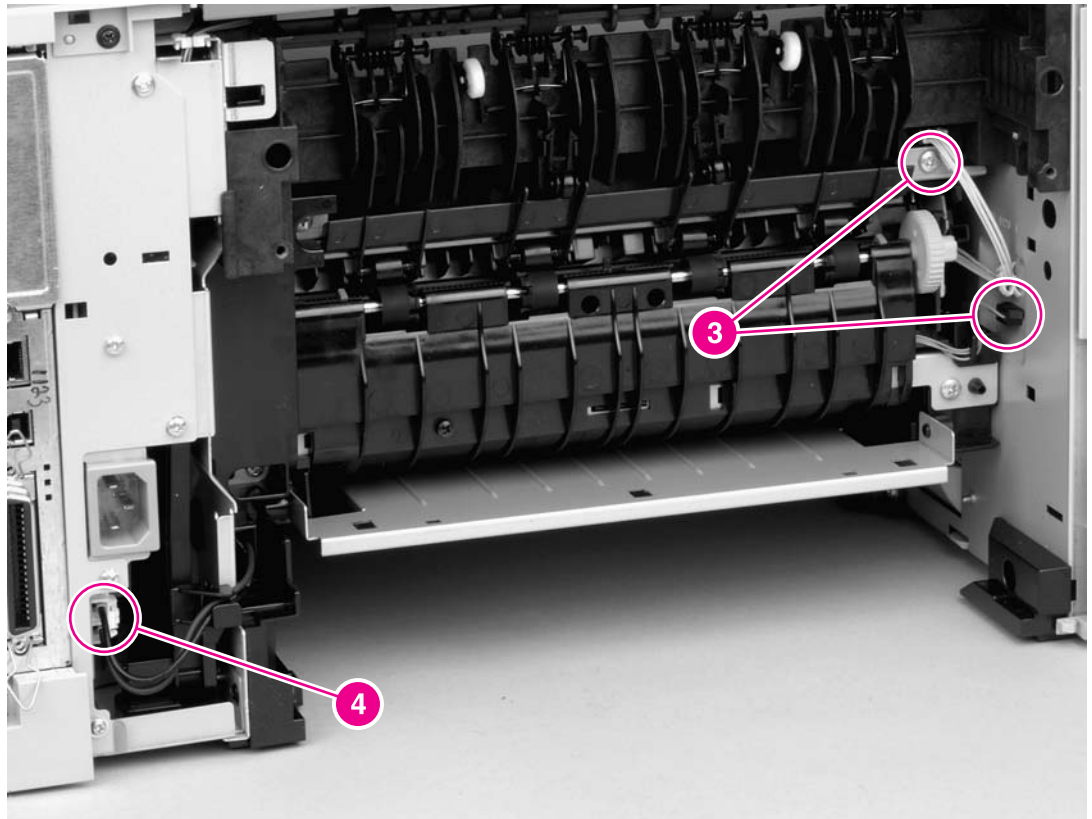

Figure 6-21. Removing the fuser (3 of 5)

6. Remove four screws (callout 5).

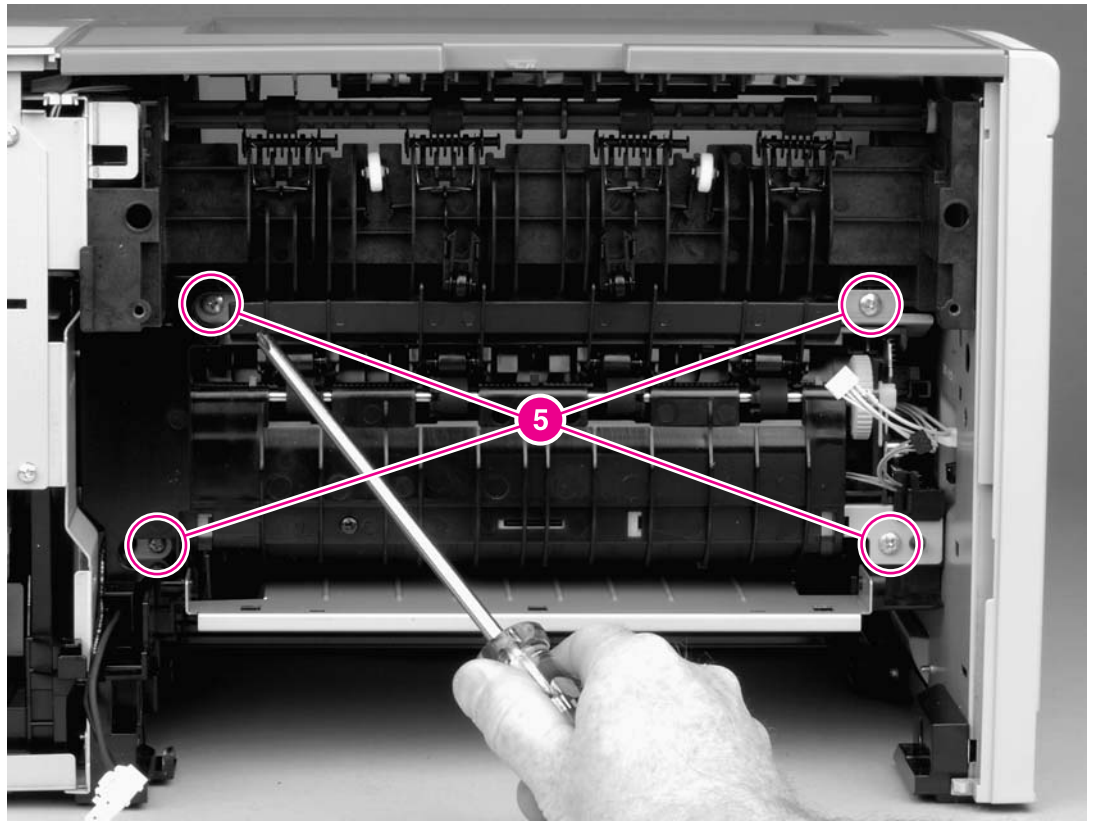

Figure 6-22. Removing the fuser (4 of 5)

7. Tilt the fuser slightly toward the back of the printer, and then slide the fuser out of the back of the printer.

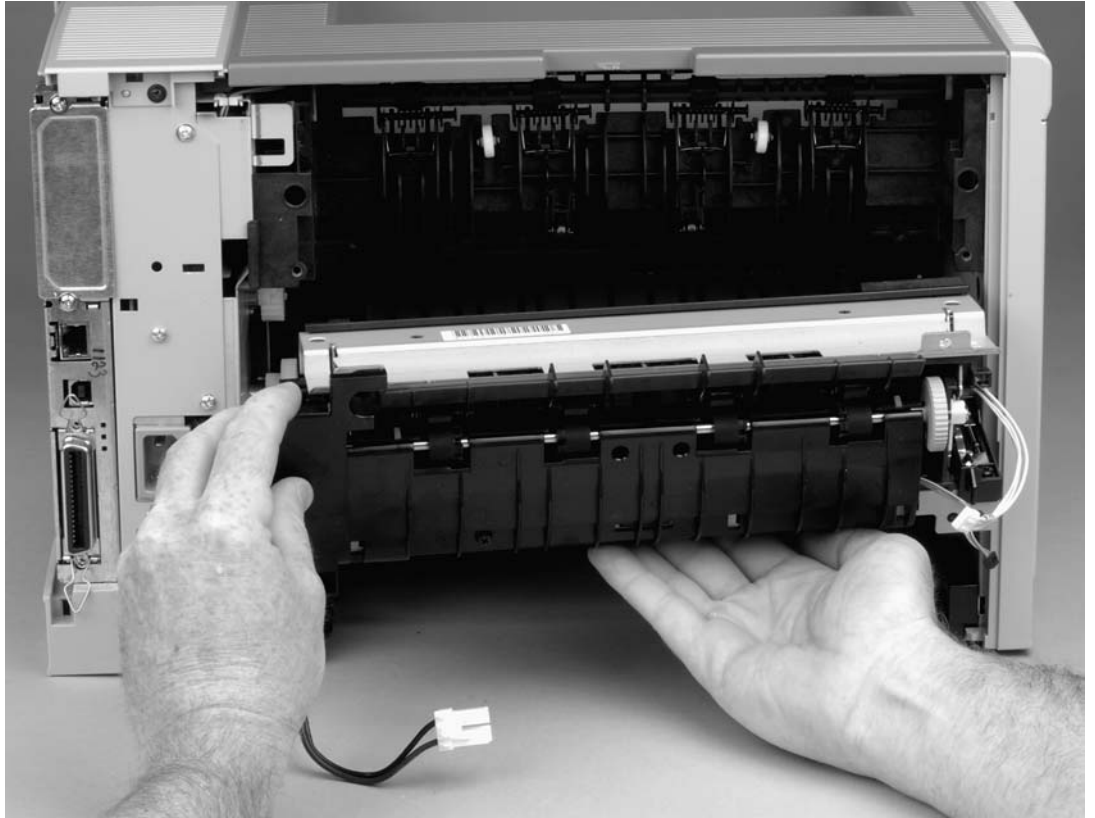

Figure 6-23. Removing the fuser (5 of 5)

Tray 1 pickup roller

1. Spread the pickup-roller locks (callout 1) on each side of the tray 1 pickup roller to release the roller.

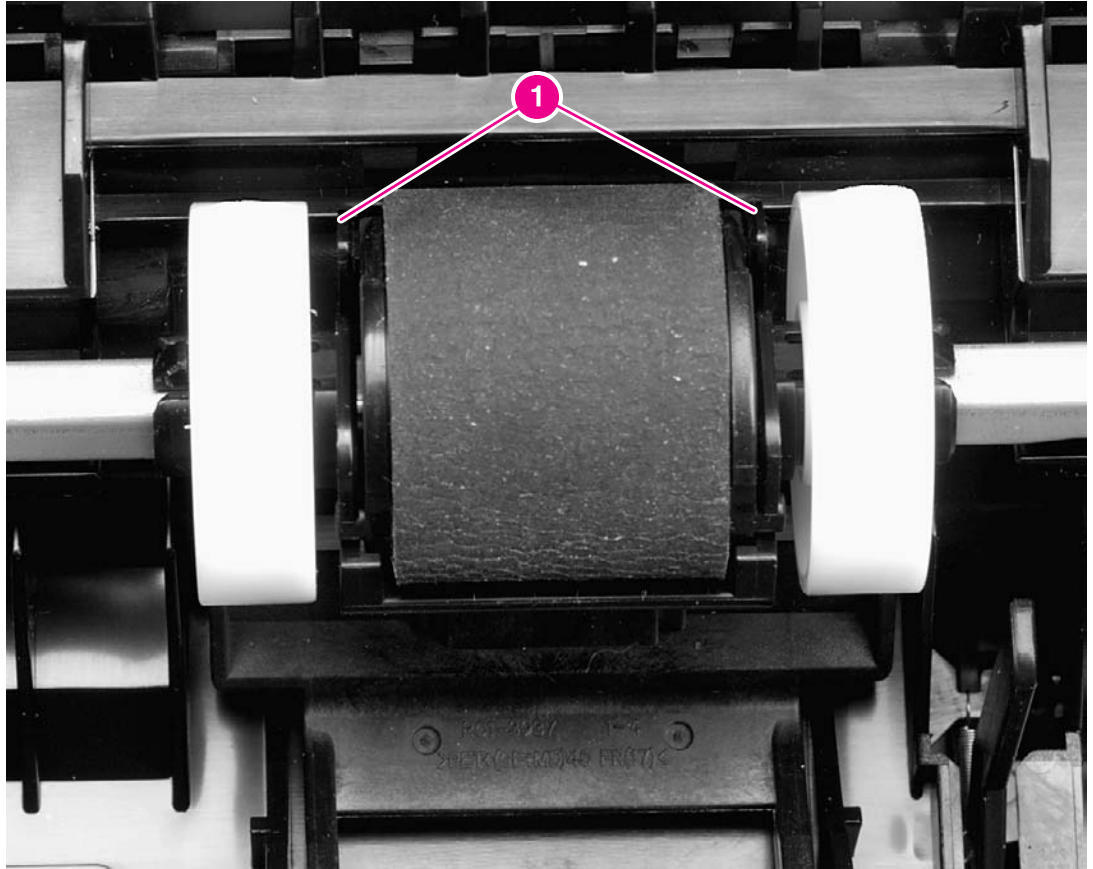

Figure 6-58.

Removing the tray 1 pickup roller

2. Rotate the top of the roller off of the shaft, and then lift the roller out of the printer.

Tray 2 pickup roller

NOTE

Also follow these instructions to remove any optional-tray pickup rollers.

1. Rotate the bushings (callout 1) on each side of the roller.

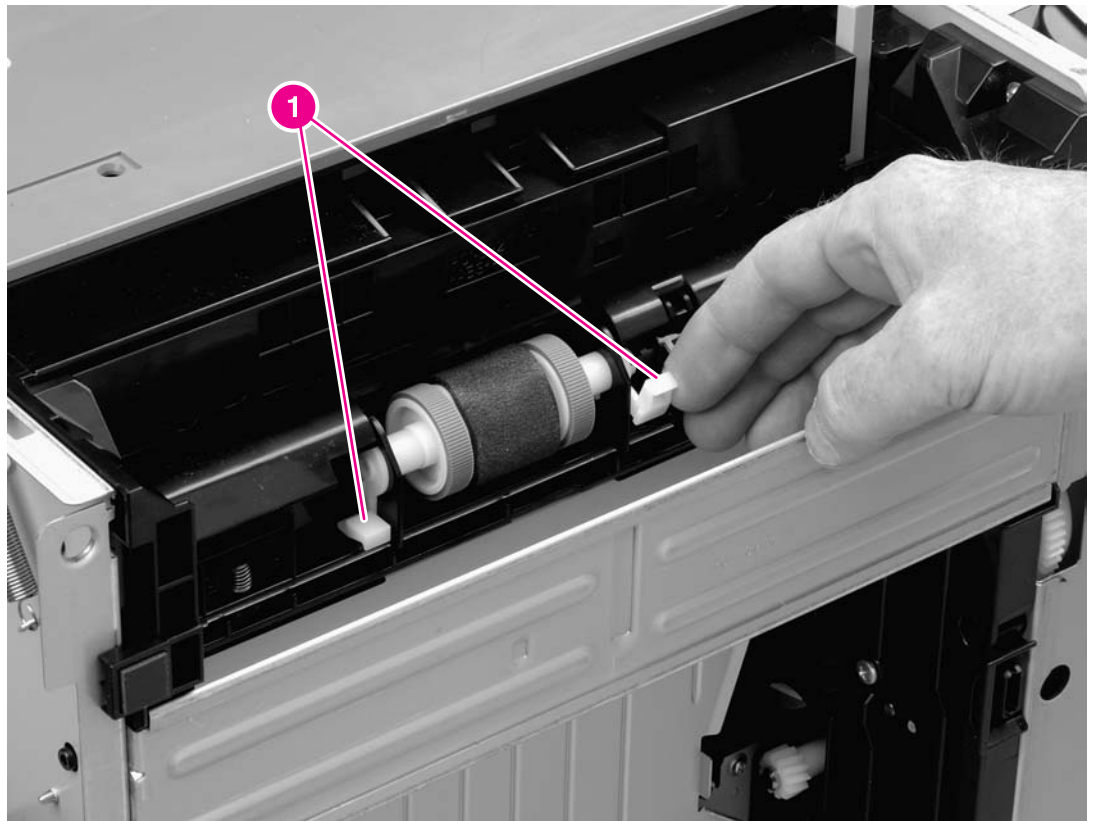

Figure 6-59. Removing the tray 2 pickup roller (1 of 2)

2. Remove the left-side bushing by sliding the bushing to the left.
3. Slide the roller and shaft toward the left until they clear the hole in the right-side bushing, and then lift the right end of the shaft.

4. Slide the roller and shaft toward the right and lift the roller and shaft together out of the printer.

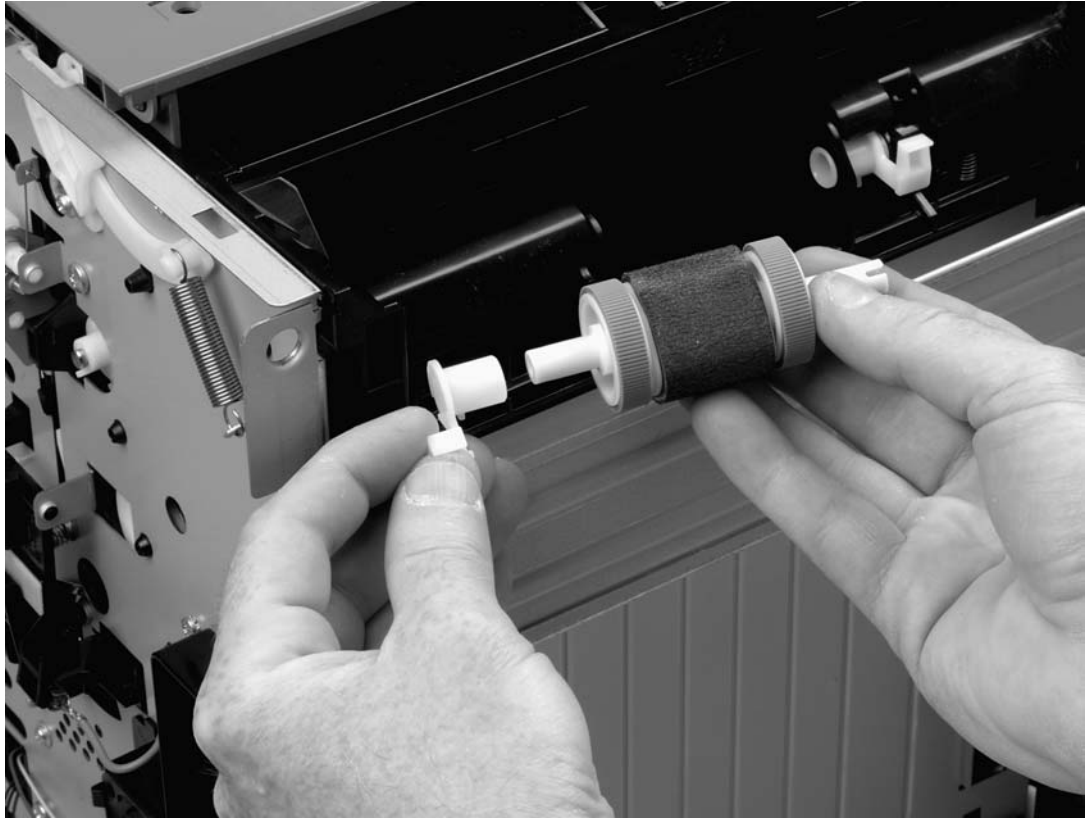

Figure 6-60. Removing the tray 2 pickup roller (2 of 2)

Separation pad

NOTE

To replace a separation pad, replace the entire separation-pad assembly.

1. Pull the tray out of the printer.
2. Remove two screws (callout 1) from the separation-pad assembly.

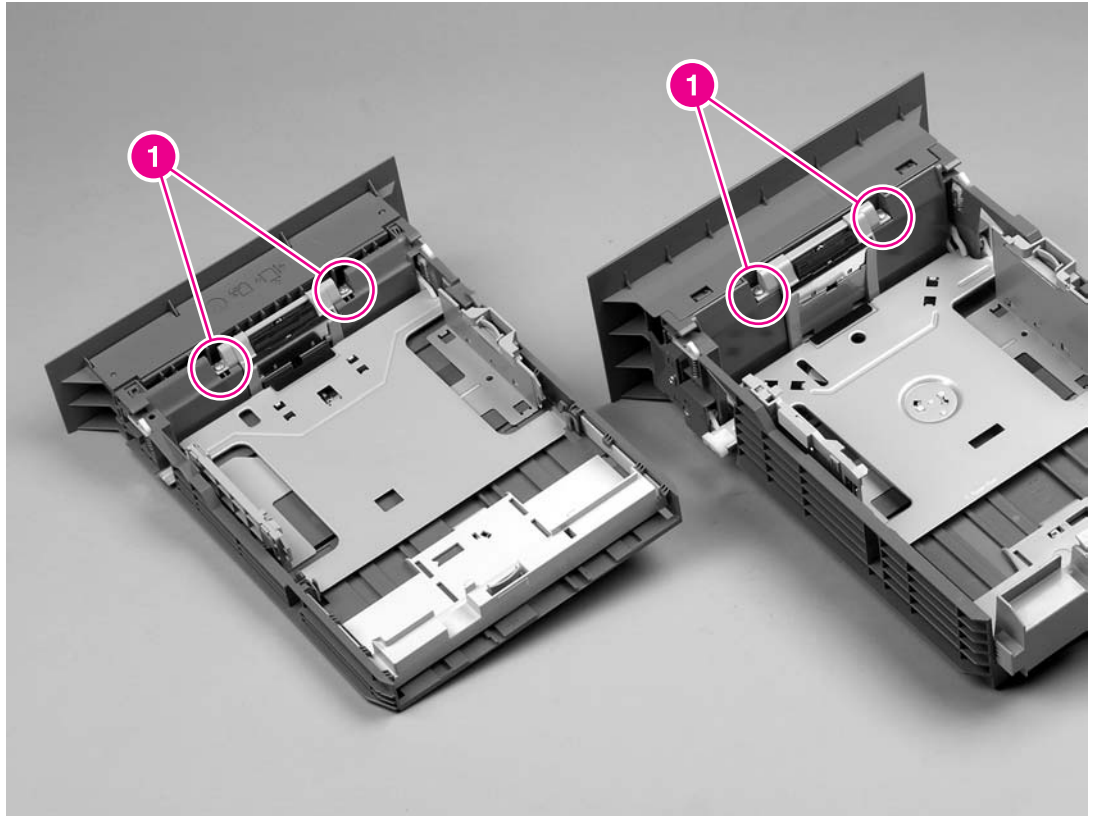

Figure 6-61.

Removing the separation pad

3. Lift the assembly out of the tray.

NOTE

Separation-pad assemblies are **not** interchangeable between 250-sheet trays and 500-sheet trays.
